

Overview

MOP and MOE series is low-cost flow meter for liquids and gases based on orifice principle.

100% Customer Satisfaction

MOP series combines a variable area flow meter (rotameter) and orifice flow meter principles. A small sized glass-tube or metal-tube variable area flow meter (rotameter) is attached to the meter tube that has an orifice on the inside. So, it's a combination of orifice flow meter and variable area flow meter (rotameter). The main components of this series are meter body with orifice, connection, taper tube (glass or metal tube), float, isolating valve and options.

MOE series combines a dP (differential pressure) indicator/transmitter and orifice meter body and comes with versatile computation and analog and digital output options.

The meter is installed in line with pipe using flange, screw or wafer (sandwich type) connections.

The material of the meter can be stainless steel, PVC, Teflon-lined, all Teflon, etc. to meet to resistance requirements to various chemical and physical properties of liquids or gases.

The meter body can be installed freely both horizontally and vertically. So, it's easy to adapt to the tough site environments.

Isolation valves are installed between the meter body and the indicator, so that there's no need to install by-pass piping for maintenance and repair of the meter and it also saves the total cost of purchasing and installing the meter.

The meter comes with various options for controlling of the process such as Reed switches.

Main Features

Low Cost & High Performance

Thanks to unique orifice by-pass system, total instrumentation cost is saved especially for medium and large sized piping

Compact Design

Small sized indicator saves space in plants.

Easy Installation

Screw, Flange or Wafer can be used to install the meter in line. There's no need for by-pass piping for repair and maintenance.

For All Flow Directions

Bottom-Top, Top-Bottom, Left-Right and Right-Left flow direction. Change of flow direction is possible even after installation.

Alarm Contact

Besides local flow indication, alarm contact (s) are available. Thus it can be used as Flow Switch.

Easy Maintenance

Simple design and limited number of parts saves maintenance workload.

High Anti-Corrosive Capability

Carbon steel, stainless steel and PVC (CPVC) versions are available for various corrosive fluid applications.

MAXIFLO

**Orifice Flow Meter
(Series MOP/MOE)**



MOP-F



MOP-C



MOP-N



MOE

Operation Principle

As shown in the figure, because liquid or gas stream inside the pipe is restricted or throttled by reducing the section area of the pipe using orifice plate, a differential pressure is generated across this orifice plate, meaning the pressure immediately downstream of the orifice is lower than that immediately upstream. The difference of pressures upstream and downstream (dP , differential pressure) corresponds to the flow rate based on Bernoulli's continuity principle. The flow rate thus can be calculated based on this differential pressure.

In MOP series (except for MOP-DP series that measures differential pressure directly using manometer), this differential pressure thus generated is converted to flow rate using variable area flow meter. The inlet (bottom) and outlet (top) of the indicator (variable area flow meter) are connected to taps placed immediately upstream and downstream of the meter body. When the fluid flows through this orifice, due to the differential pressure, the fluids flows out into the inlet of the variable area flow meter, through the tapered-tube and float, out of the outlet and back into the main stream. The fluid flowing through the tapered-tube floats the float, the height of which corresponds to the flow rate of the main stream. (For more information, please see the principle of variable area flow meters in our KA (glass-tube) and KM (metal-tube) series catalogs.)

The flow rate is engraved on the indicator scale and by reading the float position on the scale, the flow rate can be read.

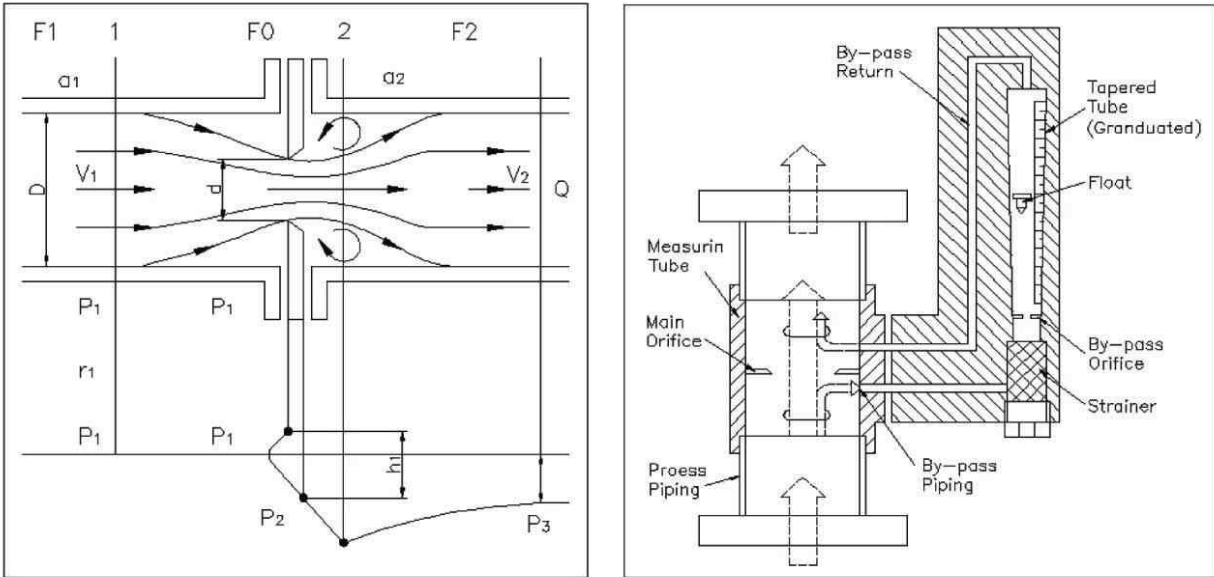

Applications

- Hot and cold water as well as air flow measurement in air conditioning
- Medium and large line measurement in general process industry
- Cooling water lines
- Water treatment process
- Pure and ultra-pure water production facilities
- Testing of fire fighting pumps
- Testing of blowers
- Etc.

Installation

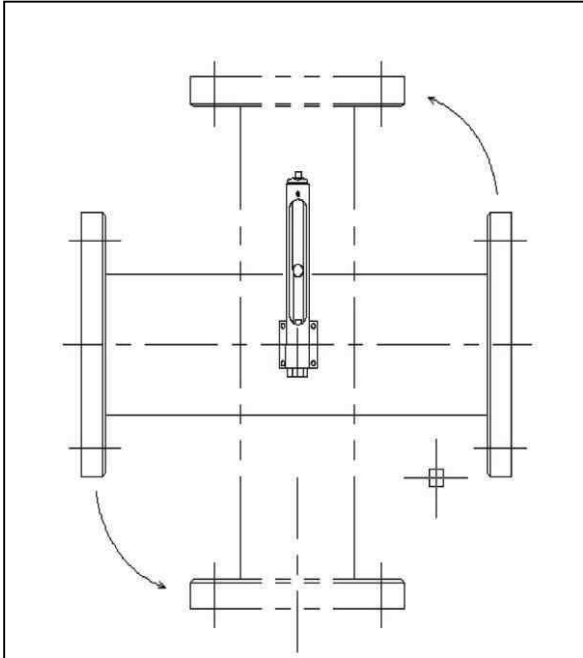

The meter can be installed either on a horizontal or vertical lines freely.

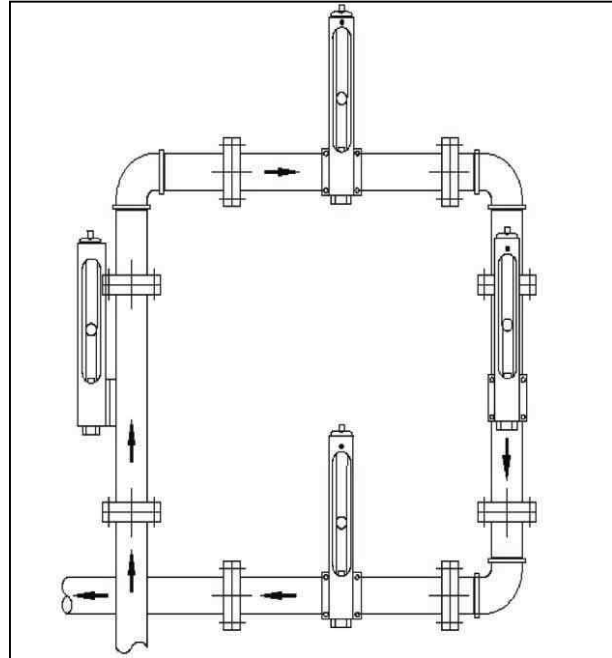

The meter can be installed for all flow directions bottom to top, top to bottom, left to right and right to left.

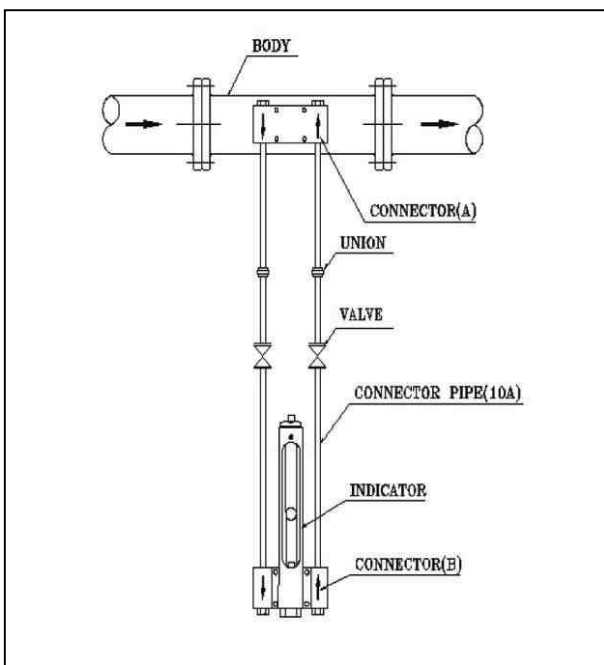

The indicator of the meter can be remotely mounted using impulse line. (In the above, the indicator is below the pipeline.)

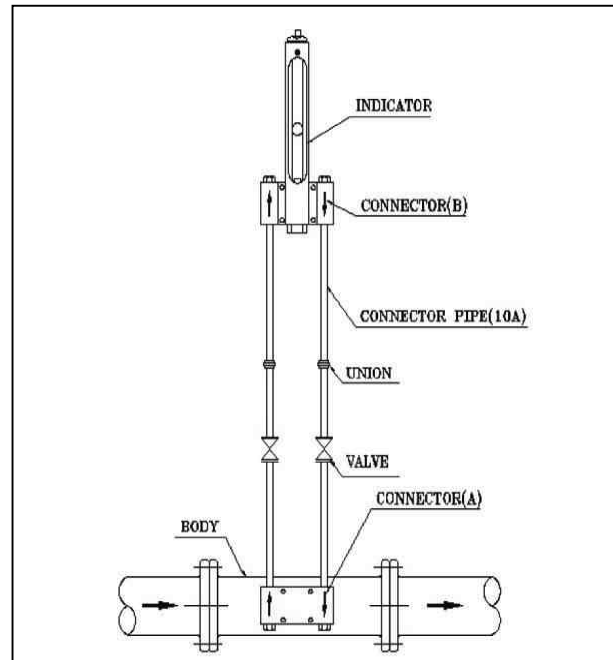

The indicator of the meter can be remotely mounted using impulse line. (In the above, the indicator is above the pipeline.)

Model Overview

Model Code	Description	Remarks
MOP	Combines variable area flow meter with orifice meter body	Indicator: Glass-tube variable area flow meter <i>(For detailed technical options of the indicator, please refer to our catalog for glass-tube rotameter series, KV.)</i>
MOP-CK	MOP series with impulse line for remote indication.	
MOP-KMS	Combines variable area flow meter with orifice meter body	Indicator: Metal-tube variable area flow meter <i>(For detailed technical options of the indicator, please refer to our catalog for metal-tube rotameter series, KMS.)</i>
MOP-CKM	MOP-KMS series with impulse line for remote indication	
MOP-DP	MOP series with manometer for indication of dP (differential pressure) instead of variable area flow meter	The scale can be with flow or manometer.
MOP-R	MOP series for fire pumps	Suitable for measuring high-pressure and high-velocity flows.
MOE	Orifice flow transmitter with digital display	Measures differential pressure, converts it to flow and processes it for display and analog/digital output.

General Specifications

Measurement Principle	Differential Pressure
Media Measured	Liquid, Gas, Steam
Turndown Ratio	5:1
Body & Connection Materials	SS41, SUS304, SUS316, SUS316L, PVC, HT-PVC, CPVC, Teflon-Lined, All Teflon, etc.
Enclosure	IP-65 (Nema-4x, weather proof)
Outputs	4-20mA, Reed Switch, etc.

Flow Rates Table

Water (m ³ /h)			Air (Nm ³ /h) @ 760 mmHg (A), 20 °C	
Size	Flow Rate	Resolution	Flow Rate	Resolution
10A	0.1 ~ 0.5	0.02	0.8 ~ 4	0.2
15A	0.2 ~ 1	0.02	2 ~ 10	0.5
20A	0.5 ~ 2.5	0.1	5 ~ 25	1
25A	1 ~ 5	0.2	10 ~ 50	2
32A	1.2 ~ 6.4	0.2	12 ~ 60	2
40A	2 ~ 10	0.5	20 ~ 100	5
50A	4 ~ 20	1	40 ~ 200	10
65A	6 ~ 32	2	60 ~ 300	20
80A	8 ~ 42	2	80 ~ 400	20
100A	16 ~ 80	5	160 ~ 800	50
125A	25 ~ 125	5	250 ~ 1250	50
150A	35 ~ 180	10	350 ~ 1700	100
200A	60 ~ 320	20	600 ~ 2800	200
250A	90 ~ 480	20	900 ~ 5000	200
300A	160 ~ 820	20	1600 ~ 7800	200
350A	200 ~ 1000	50	2000 ~ 9500	500
400A	300 ~ 1500	100	3000 ~ 14000	1000
450A	400 ~ 2000	100	4000 ~ 19000	1000
500A	500 ~ 2500	100	5000 ~ 24000	1000

MOP Series (Orifice Flow Meter with Indicator using Glass Tube Rotameter)

MOP-N

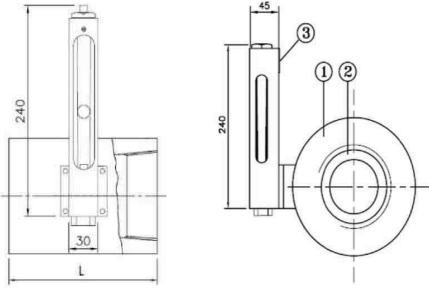

Screw Connection

Dimensions, Weight and Materials (Weight based on SUS304)

Size	L (mm)	Weight (Kg)	Part	Description	Material
10A	70	2	1	Body	SUS304, SUS316, SS41
15A	70	2			
20A	70	2			
25A	70	2.5	2	Orifice	SUS304, SUS316, SS41
32A	75	3			
40A	85	3.5			
50A	90	4			
65A	100	5	3	Indicator	SUS304, SUS316, SS41
80A	110	6			
100A	120	86			

Specifications

Sizes	Pressure	Temperature	Accuracy
10 ~ 100A (Over this range, optional)	Max. 10 KgF/cm2G (20 KgF/cm2G Optional)	Max. 200℃	±2%, F.S

MOP-F

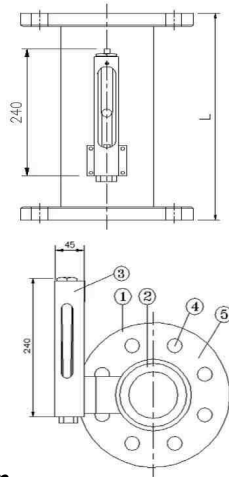

Flange Connection

Dimensions, Weight and Materials (Weight based on SUS304)

Size	L (mm)	Weight (Kg)	Size	L (mm)	Weight (Kg)	Part	Desc.	Material
10A	520	3	125A	540	23	1	Body	SUS304, SUS316, SS41
15A	520	4	150A	540	25			
20A	520	5	200A	540	35			
25A	520	6	250A	540	50	2	Orifice	SUS304, SUS316, SS41
32A	520	7	300A	540	63			
40A	520	8	350A	540	80	3	Indicator	SUS304, SUS316, SS41
50A	520	10	400A	540	95			
65A	540	12	450A	540	120	4	Bolt	SS41, SUS304
80A	540	13	500A	540	130			
100A	540	16	600A	540	170	5	Flange	SUS304, SUS316, SS41

Specifications

Sizes	Pressure	Temperature	Accuracy
10 ~ 600A (Over this range, optional)	Max. 10 KgF/cm2G (20 KgF/cm2G Optional)	Max. 200℃	±2%, F.S

MOP-C

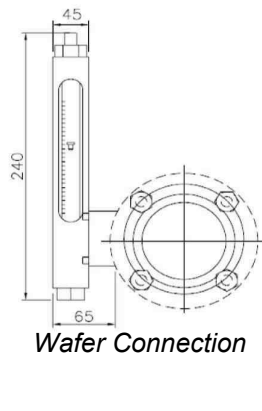

Wafer Connection

Dimensions, Weight and Materials (Weight based on SUS304)

Size	L (mm)	Weight (Kg)	Size	L (mm)	Weight (Kg)	Part	Desc.	Material
10A	60	2.5	125A	60	9	1	Indicator	SS41, SUS304, SUS316
15A	60	3	150A	60	10			
20A	60	3	200A	60	15			
25A	60	4	250A	60	20	2	Glass	Pyrex
32A	60	4	300A	60	23			
40A	60	5	350A	80	25	3	Float	Mano Ball, SUS304
50A	60	5	400A	80	34			
65A	60	6	450A	80	40	4	Flange	As Material Selection
80A	60	7	500A	80	48			
100A	60	8	600A	80	60	5	Body	As Material Selection
						6	Bolt	SS41, SS304

Specifications

Sizes	Pressure	Temperature	Accuracy
10 ~ 600A (Over this range, optional)	Max. 10 KgF/cm2G (20 KgF/cm2G Optional)	Max. 200℃	±2%, F.S

Model Selection Guide

MOP	Description	Code
Size		mm
Connection	Screw	N
	Flange	F
	Wafer (Sandwich)	C
Material	SS41	A
	SUS304	B
	SUS316	C
	SUS316L	D
	XP	PVC
	XT	Teflon
Options	Isolator Valve (Cock Valve)	B
	1-Point Alarm	R1
	2-Point Alarm	R2

MOP-CK Series (MOP series with Remote Glass Tube Roatmeter Indicator)



Model Selection Guide		
MOP-CK	Description	Code
Size		mm
Connection	Screw	N
	Flange	F
	Wafer (Sandwich)	C
Flow Direction of the Main Pipe	Bottom to Top (Vertical)	A
	Left to Right (Horizontal)	B
	Right to Left (Horizontal)	C
	Top to Bottom (Vertical)	D
Position of the Indicator	Above Main Pipe	1
	Below Main Pipe	2
Type of Tapping	1D x 1/2D Tap *1	P
	Corner Tap with Orifice Ring*2	C
	Flange Tap*3	F
	Vena Tap*4	V

Notes

- *1: Suitable for 100A ~ 500A main pipes
- *2: Suitable for 50A ~ 500A main pipes
- *3: Suitable for 50A ~ 500A main pipes
- *4: Suitable for 200A ~ 500A main pipes

Flow Rates Table for Water (m3/h)

Size	@ DP 1000 mmAq	@1500 mmAq	@2000 mmAq	@2500 mmAq	@3000 mmAq	@5000 mmAq
50A	1.8 ~ 1.5	2 ~ 18	2.4 ~ 20	2.6 ~ 23	3 ~ 25	4 ~ 30
65A	3.5 ~ 24	4 ~ 30	5 ~ 35	5.2 ~ 38	6 ~ 40	8 ~ 50
80A	4.2 ~ 32	5 ~ 40	6 ~ 45	6.5 ~ 50	7 ~ 55	10 ~ 70
100A	7 ~ 55	8 ~ 70	9 ~ 80	10 ~ 90	12 ~ 100	15 ~ 120
125A	12 ~ 80	15 ~ 100	18 ~ 120	20 ~ 130	22 ~ 140	30 ~ 180
150A	16 ~ 120	20 ~ 150	25 ~ 180	26 ~ 190	30 ~ 210	40 ~ 250
200A	35 ~ 200	40 ~ 250	50 ~ 280	55 ~ 320	60 ~ 350	80 ~ 450
250A	50 ~ 300	60 ~ 400	70 ~ 450	80 ~ 500	85 ~ 550	100 ~ 700
300A	65 ~ 450	80 ~ 550	90 ~ 650	100 ~ 700	120 ~ 800	140 ~ 1000
350A	85 ~ 550	100 ~ 700	120 ~ 800	130 ~ 900	140 ~ 1000	180 ~ 1300
400A	120 ~ 700	150 ~ 900	180 ~ 1100	200 ~ 1200	220 ~ 1300	250 ~ 1600
450A	160 ~ 1000	200 ~ 1200	240 ~ 1400	260 ~ 1500	280 ~ 1700	350 ~ 2200
500A	350 ~ 1200	400 ~ 1500	500 ~ 1700	520 ~ 1900	560 ~ 2100	700 ~ 2600

Flow Rates Table for Air (Nm3/h at 1 atm, 0 °C)

Size	@ DP 1000 mmAq	@1500 mmAq	@2000 mmAq	@2500 mmAq
50A	25 ~ 280	35 ~ 390	42 ~ 470	60 ~ 650
65A	45 ~ 450	64 ~ 640	76 ~ 760	110 ~ 1050
80A	60 ~ 640	85 ~ 900	100 ~ 1100	150 ~ 1500
100A	100 ~ 1100	140 ~ 1500	170 ~ 1800	250 ~ 2500
125A	150 ~ 1700	220 ~ 2300	270 ~ 2800	370 ~ 3800
150A	210 ~ 1300	300 ~ 3300	360 ~ 4000	50 ~ 5500
200A	380 ~ 4000	500 ~ 5500	600 ~ 6500	850 ~ 9000
250A	550 ~ 6400	800 ~ 8800	1000 ~ 10000	1400 ~ 14000
300A	900 ~ 9000	1200 ~ 12000	1500 ~ 15000	2000 ~ 20000
350A	1100 ~ 11000	1500 ~ 15000	1800 ~ 18000	2500 ~ 25000
400A	1500 ~ 15000	2000 ~ 20000	2400 ~ 24000	3400 ~ 33000
450A	1800 ~ 19000	2600 ~ 26000	3000 ~ 30000	4500 ~ 43000
500A	2200 ~ 23000	3200 ~ 33000	4000 ~ 40000	5500 ~ 55000

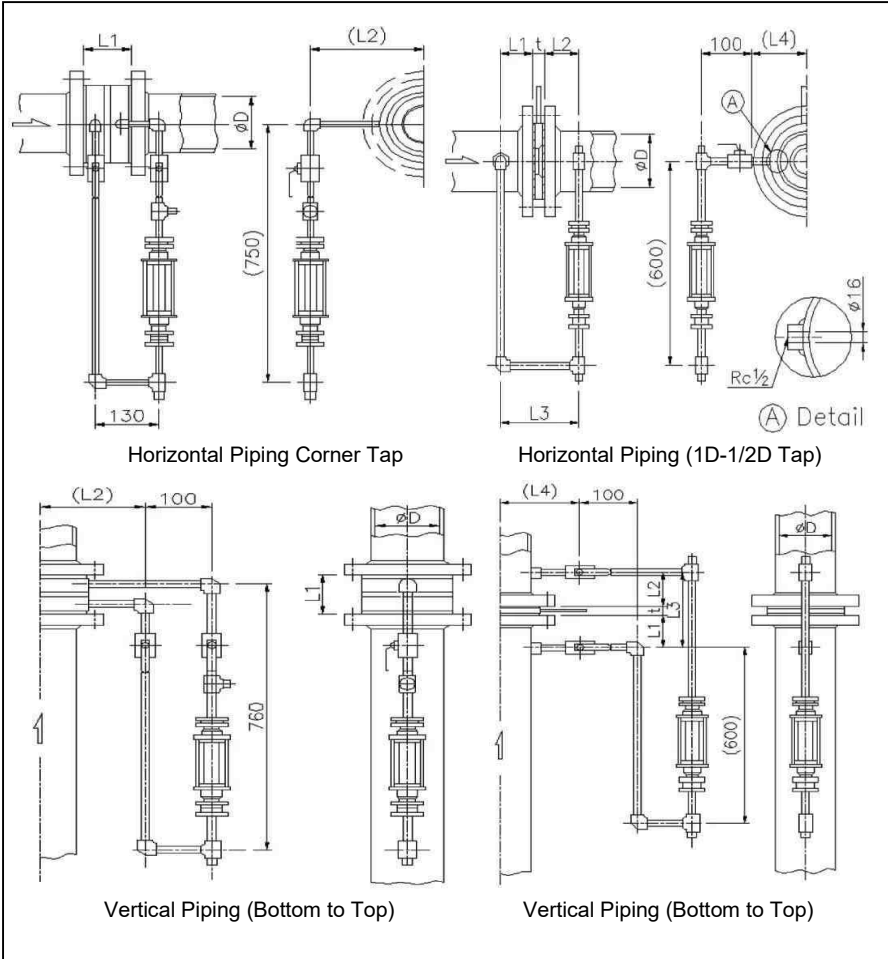

Dimensions

Size	L1	L2
50A	68	125
65A	68	135
80A	68	140
100A	71	150
125A	71	165
150A	71	180
200A	71	205
250A	71	245
300A	71	265
350A	71	290
400A	71	325
450A	71	355
500A	71	380

Size	L1	L2	T	L3	L4
50A	/	/	/	/	/
65A	/	/	/	/	/
80A	/	/	/	/	/
100A	102	47	9	158	110
125A	59	59	9	196	130
150A	152	71	10	233	150
200A	202	95	10	307	170
250A	251	119	11	381	210
300A	302	144	11	457	230
350A	337	162	11	510	250
400A	388	186	12	586	280
450A	438	212	12	662	310
500A	489	237	12	738	350

Scope of Supply

No	Part	Material		
		Class 1	Class 2	Class 3
1	Main Pipe	Customer's Scope of Supply		
2	Orifice Flange			
3	Flange Gasket			
4	Main Orifice	SUS304	SUS304	SUS316
5	Orifice Ring	SS400	SUS304	SUS316
6	Ball Valve	BsBFE2	SCS13A	SCS14A
7	Bypass Piping	SGP or STGP	SUS304	SUS316
8	Bypass Orifice	SUS304	SUS304	SUS316
9	Gasket	For Liquids: Non-Asbestos For Gases: NBR or Viton		
10	Indicator	SCS13/S S400	SCS13/S US304	SCS14/S US316

Notes:

Gaskets between main pipe orifice (or orifice ring) and piping flanges as well as bolts and nuts for installation are customer's scope of supply unless otherwise specified.

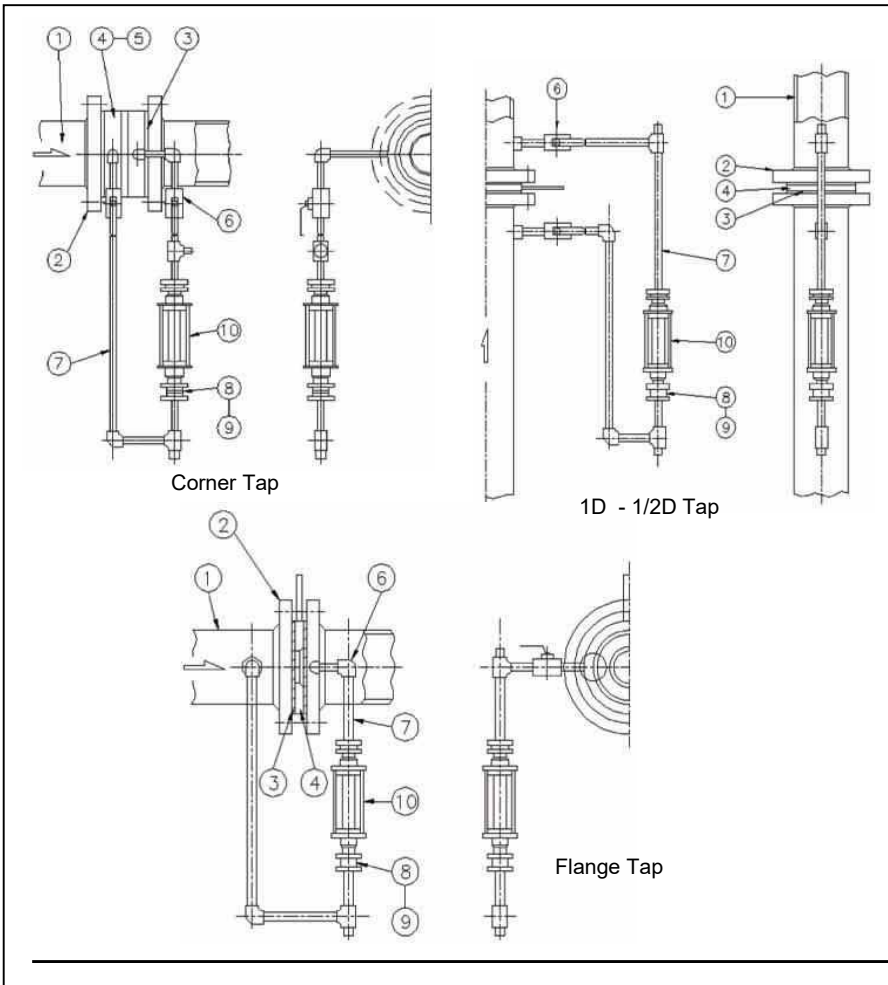

MOP-KMF-F

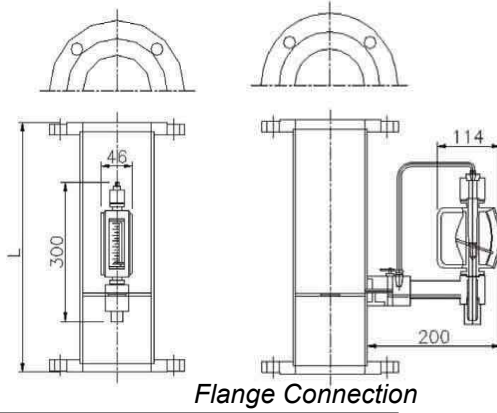

Flange Connection

Dimensions (Weight based on SS) - Flanged

Size	L2 (mm)	Weight (Kg)	Size	L2 (mm)	Weight (Kg)
10A	520	3	125A	540	23
15A	520	4	150A	540	25
20A	520	5	200A	540	35
25A	520	6	250A	540	50
32A	520	7	300A	540	63
40A	520	8	350A	540	80
50A	520	10	400A	540	95
65A	540	12	450A	540	120
80A	540	13	500A	540	130
100A	540	16	600A	540	170

MOP-KMS-N

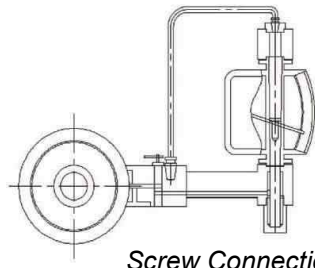
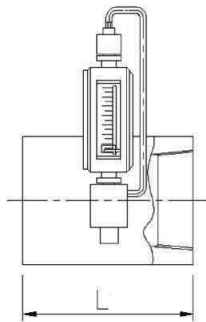

Screw Connection

Dimensions (Weight based on SS) - Screwed

Size	L (mm)	Weight (Kg)
10A	70	2
15A	70	2
20A	70	2
25A	70	2.5
32A	74	3
40A	85	3.5
50A	90	4
65A	100	5
80A	110	6
100A	120	8

MOP-KMS-N

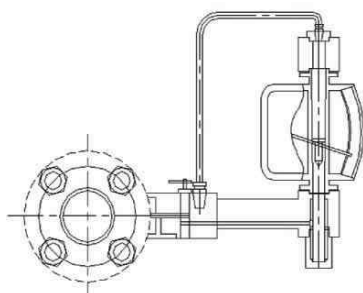
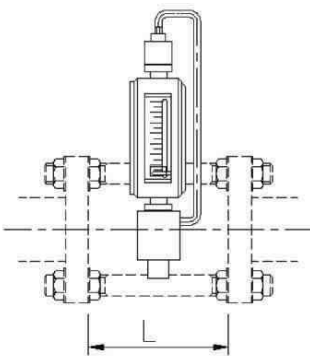

Wafer Connection

Dimensions (Weight based on SS) - Wafered

Size	L2 (mm)	Weight (Kg)	Size	L2 (mm)	Weight (Kg)
10A	60	2.5	125A	60	9
15A	60	3	150A	60	10
20A	60	3	200A	60	15
25A	60	4	250A	60	20
32A	60	4	300A	60	23
40A	60	5	350A	80	25
50A	60	5	400A	80	34
65A	60	6	450A	80	40
80A	60	7	500A	80	48
100A	60	8	600A	80	60

Model Selection Guide

MOP-KMS	Description	Code
Size		mm
Connection	Screw	N
	Flange	F
	Wafer (Sandwich)	C
Material	SS41	A
	SUS304	B
	SUS316	C
	SUS316L	D
	PVC	XP
	Teflon	XT
Option	Bypass Cock Valve	B
	3-way Valve	W
	4-20mA Output Signal	S
	1- Point Alarm	R1
	2-Point Alarm	R2

Main Specifications

Line Sizes	10A ~ 500A (Above this size, optional)
Fluid	Liquids and Gases
Flange	JIS, ANSI, DIN, etc.
Temperature	-5°C ~ 300°C
Pressure	20 KgF/cm ² (above this available as option)
Material	Body & Flange – SUS304, SUS316, SUS316L, SS41 Transmitter Housing – SUS304, SUS316, SUS316L
Accuracy	±2%, F.S

Note:

For detailed technical options of the indicator, please refer to our catalog for metal tube rotameter series, KMS.

MOP-CKM Series (MOP-CK series with Remote Metal Tube Roatmeter Indicator)



Model Selection Guide		
MOP-CKM	Description	Code
Size		mm
Flow Direction of Main Piping	Bottom to Top	A
	Left to Right	B
	Right to Left	C
	Top to Bottom	D
Position of the Indicator	Above Main Pipe	1
	Below Main Pipe	2
Tapping	1D x 1/2D Tap *1	P
	Corner Tap (with orifice ring) *2	C
	Flange Tap *3	F
	Vena Tap *4	V
Option	4-20mA Output Signal	S
	Explosion Proof (Exd IIC T6)	EX

- Notes
 *1: Suitable for 100A ~ 500A main pipes
 *2: Suitable for 50A ~ 500A main pipes
 *3: Suitable for 50A ~ 500A main pipes
 *4: Suitable for 200A ~ 500A main pipes

Flow Rates Table

Size	Water (m³/h)		Air (N m³/h, at 1 atm, 0°C)	
	40 KPa	60 KPa	40 KPa	60 KPa
50A	5 ~ 30	5 ~ 40	80 ~ 800	100 ~ 1000
65A	6 ~ 50	8 ~ 60	130 ~ 1100	160 ~ 1400
80A	8 ~ 70	10 ~ 90	180 ~ 1700	220 ~ 2200
100A	12 ~ 120	15 ~ 150	300 ~ 3000	350 ~ 3500
125A	20 ~ 160	30 ~ 200	4500 ~ 4000	600 ~ 5000
150A	30 ~ 250	40 ~ 300	600 ~ 5500	700 ~ 7000
200A	40 ~ 400	50 ~ 500	1000 ~ 10000	1200 ~ 12000
250A	60 ~ 600	80 ~ 800	1600 ~ 15000	2000 ~ 20000
300A	90 ~ 900	120 ~ 1200	2400 ~ 20000	3000 ~ 25000
350A	120 ~ 1200	150 ~ 1500	3000 ~ 23000	4000 ~ 35000
400A	150 ~ 1500	200 ~ 2000	4000 ~ 29000	5000 ~ 45000
450A	200 ~ 2000	250 ~ 2500	5000 ~ 38000	6000 ~ 55000
500A	250 ~ 2500	300 ~ 3000	6000 ~ 50000	7000 ~ 70000

Max dP (differential pressure) for liquids and gases 40 kPa or 60 kPa

Dimensions

Size	L1	L2
50A	68	125
65A	68	135
80A	68	140
100A	71	150
125A	71	165
150A	71	180
200A	71	205
250A	71	245
300A	71	265
350A	71	290
400A	71	325
450A	71	355
500A	71	380

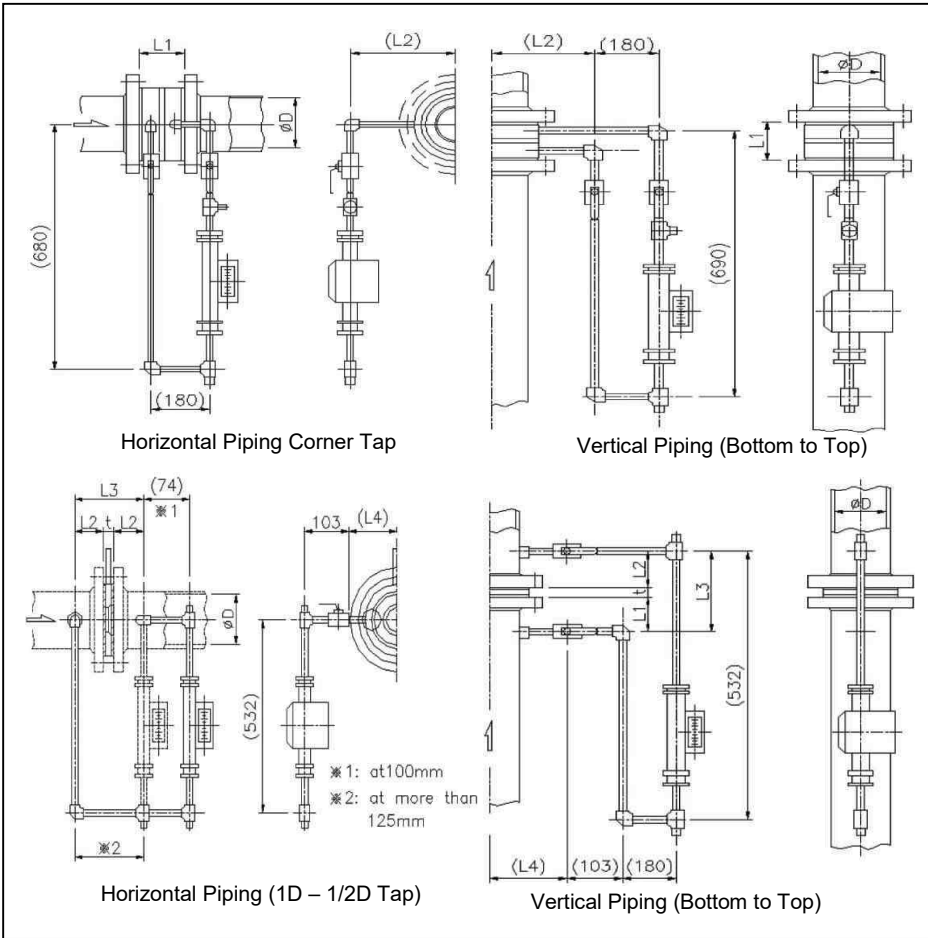

Size	L1	L2	T	L3	L4
50A	/	/	/	/	/
65A	/	/	/	/	/
80A	/	/	/	/	/
100A	102	47	9	158	110
125A	59	59	9	196	130
150A	152	71	10	233	150
200A	202	95	10	307	170
250A	251	119	11	381	210
300A	302	144	11	457	230
350A	337	162	11	510	250
400A	388	186	12	586	280
450A	438	212	12	662	310
500A	489	237	12	738	350

Scope of Supply

No	Part	Material		
		Class 1	Class 2	Class 3
1	Main Pipe	Customer's Scope of Supply		
2	Orifice Flange			
3	Flange Gasket			
4	Main Orifice	SUS304	SUS304	SUS316
5	Orifice Ring	SS400	SUS304	SUS316
6	Ball Valve	BsBFE2	SCS13A	SCS14A
7	Bypass Piping	SGP or STGP	SUS304	SUS316
8	Bypass Orifice	SUS304	SUS304	SUS316
9	Gasket	For Liquids: Non-Asbestos For Gases: NBR or Viton		
10	Indicator	SCS13/S S400	SCS13/S US304	SCS14/S US316

Notes:

Gaskets between main pipe orifice (or orifice ring) and piping flanges as well as bolts and nuts for installation are customer's scope of supply unless otherwise specified.

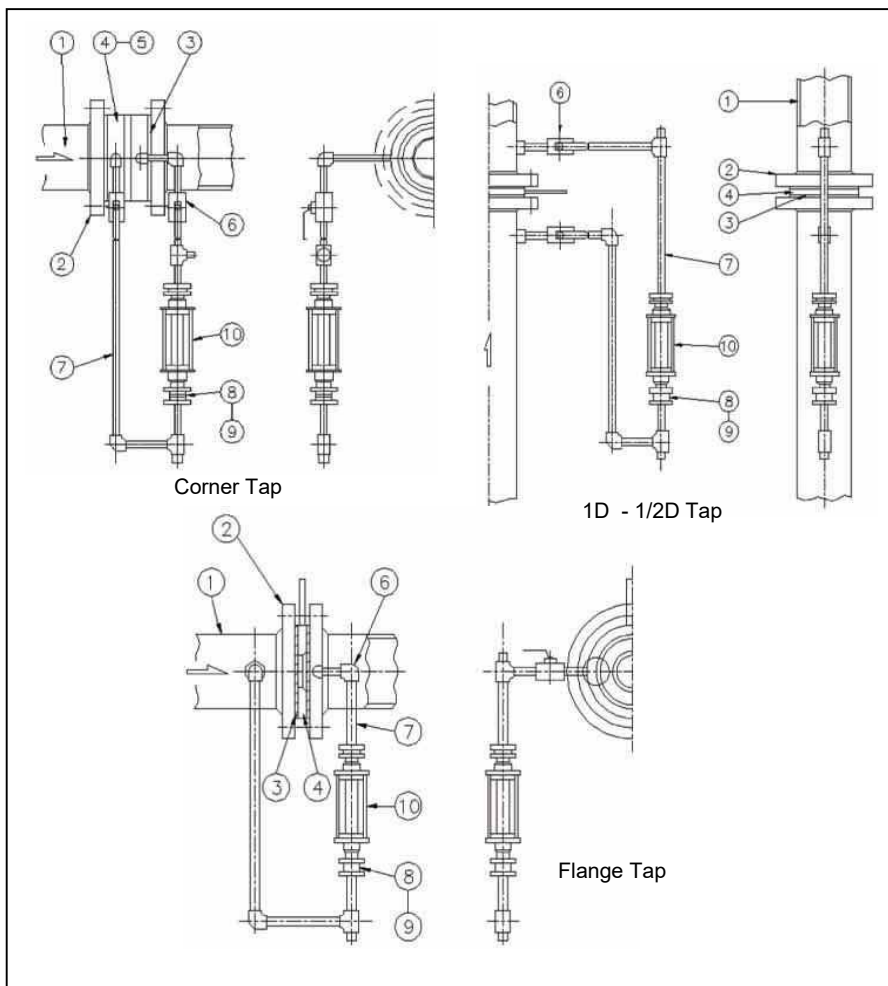

MOP-DP Series (Orifice Meter with dP (differential pressure) Indicator Option)



MOP-DP-FI

Model Selection Guide		
MOP-DP	Description	Code
Size		mm
Indicator	Flow Indicator	FI
	Manometer Indicator	MM
	Ø150 Dial Indicator	YJ
	Ø100 Dial Indicator	MJ
	Remote Panel Indicator	PJ
Material	SUS304	B
	SUS316	C
	SUS316L	D
Option	Cock Valve	B
	3-Way Valve	Y
	1-Point Contact	R1
	2-Point Contact	R2

Installations



MOP-DP-FI-YJ



MOP-DP-YJ

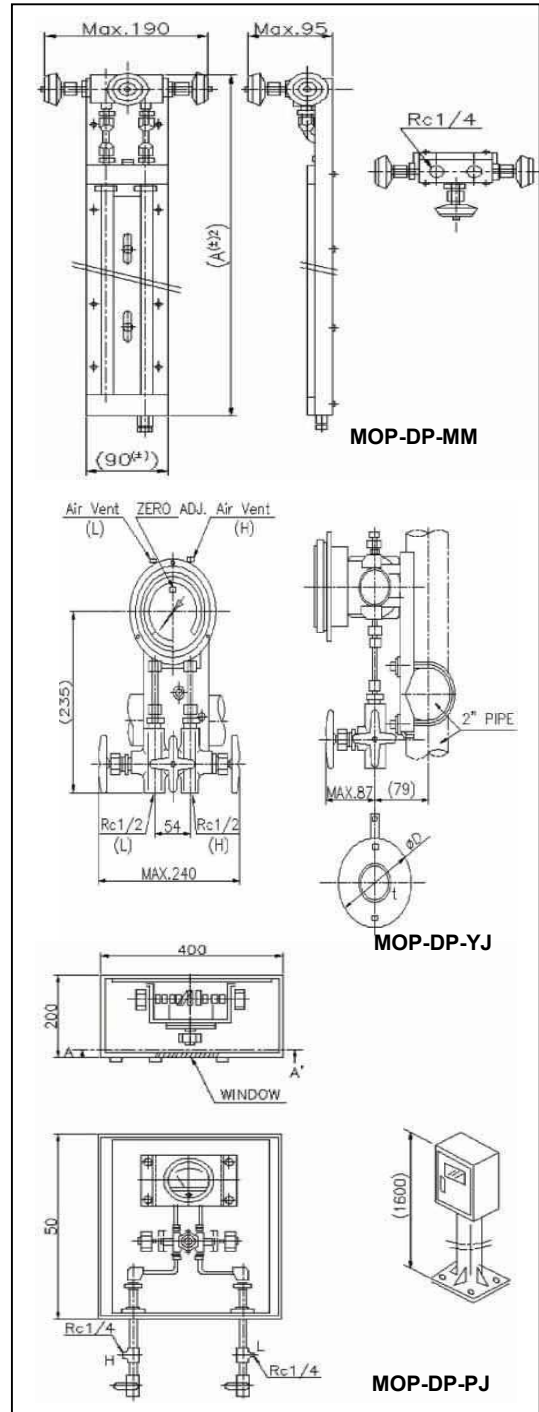

Main Specifications

Line Sizes	10A ~ 500A (Above this size, optional)
Fluid	Liquids and Gases
Flange	JIS, ANSI, DIN, etc.
Temperature	-5°C ~ 100°C
Pressure	20 KgF/cm ² (above this available as option)
Material	Body & Flange – SUS304, SUS316, SUS316L, SS41 Indicator Housing – SUS304 3-way Valve – SUS304
Accuracy	±2%, F.S

Note:

For detailed technical options of the indicator, please refer to our catalog for metal tube rotameter series, KMS.

MOP-R Series (Orifice Meter for Fire Pumps)



Flow Rate and Size Table

Size	25A	32A	40A	50A	65A	80A	100A	125A	150A
Flow Rate (L/min)	35 ~ 180	70 ~ 360	110 ~ 550	220 ~ 1100	450 ~ 2200	700 ~ 3300	900 ~ 4500	1200 ~ 6000	2000 ~ 10000
Resolution (L/min)	5	10	10	20	50	100	100		
Length (L)	N	70	74	85	90	100	100	120	
	F	520	520	520	520	540	540	540	540

N - Screw Connection
F - Flange Connection

MOP-R-N

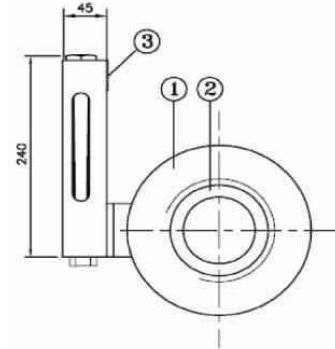
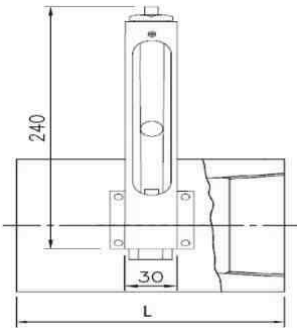

Dimensions and Weights based on SUS304

Size	L (mm)	Weight (Kg)
25A	70	2.5
32A	74	3
40A	85	3.5
50A	90	4
65A	100	5
80A	110	6
100A	120	8

MOP-R-F

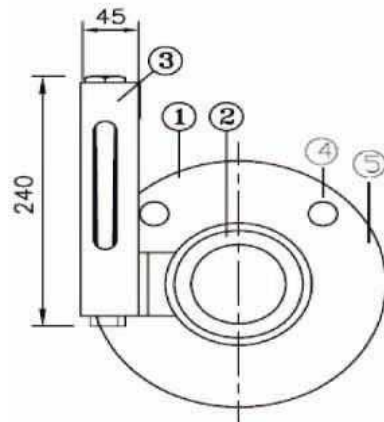
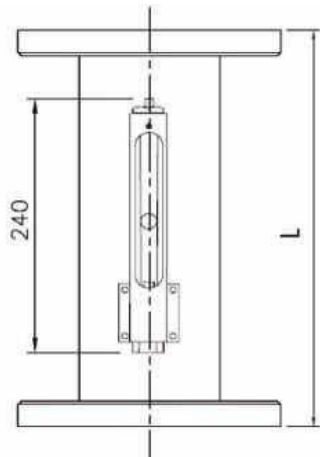

Dimensions and Weights based on SUS304

Size	L (mm)	Weight (Kg)	Size	L (mm)	Weight (Kg)
25A	520	6	150A	540	25
32A	520	7	200A	540	35
40A	520	8	250A	540	50
50A	520	10	300A	540	63
65A	540	12	350A	540	80
80A	540	13	400A	540	95
100A	540	16	450A	540	120
125A	540	23	500A	540	130

MOE Series (Orifice Flow Transmitter)



MOE-BG-F-2-T



MOE-BS-F-2-TR

Model Selection Guide		
MOE	Description	Code
Size		mm
Fluid	Gas	BG
	Liquid	BL
	Steam	BS
Connection	Flange	F
	Screw	N
	Wafer	C
Material	SS41	1
	SUS304	2
	SUS316	3
	SUS316L	4
Option	LCD Display (Flow Rate & Total), 4-20mA, Pulse Output	T
	LCD Display (Flow Rate only), 4-20mA, Pulse Output, RS-485	TR
	Cock Valve	B
	3-Way Valve	Y

Main Specifications

General	Performance	Transmitter
dP Range: 0 ~ 15000 mmH2O Max. Line Pressure: 35 barg	Linearity: ±0.5%, F.S Repeatability: ±0.1%, F.S Hysteresis: ±0.5%, F.S Thermal Effect: ±0.5%, F.S Accuracy: ±1.0%, Reading	Display: 2 line, 12-digit LCD (Flow Rate & Total) Ambient Temperature: 0°C ~ 60°C Output: 4-20mA, Pulse, RS-485

Dimensions

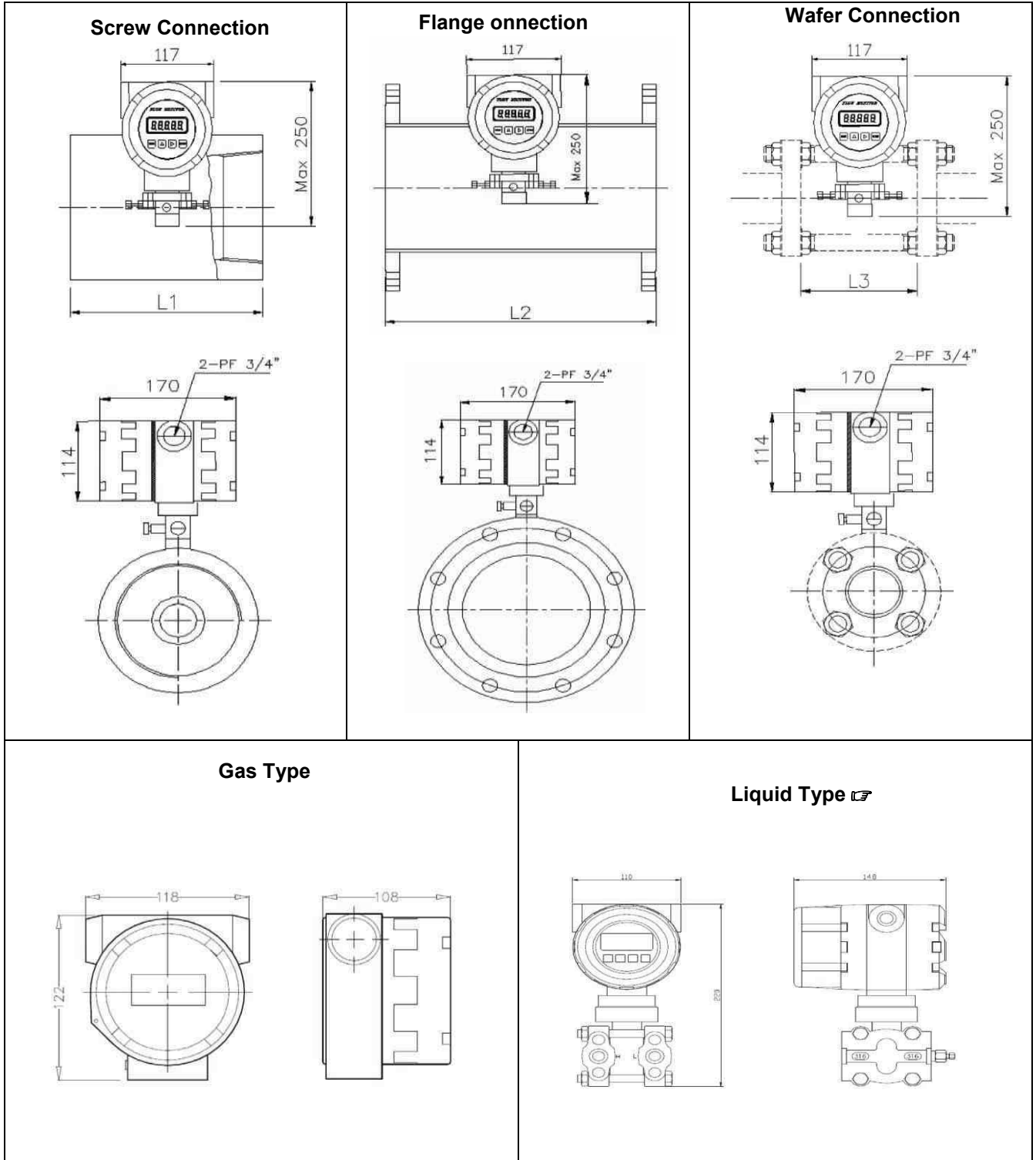

Flow Rates Table

Size	Water (m ³ /h)		Air (N m ³ /h, at 1 atm, 0 °C)		
	dP 1000 mmAq	dP 4000 mmAq	dP 500 mmAq	dP 1000 mmAq	dP 4000 mmAq
10A	0.15 ~ 0.5	0.1 ~ 0.5	2.3 ~ 9.0	3.5 ~ 12	4.5 ~ 16
15A	0.2 ~ 1.1	0.2 ~ 1.0	3.2 ~ 20	4.5 ~ 28	6.0 ~ 39
20A	0.5 ~ 2.4	0.5 ~ 2.5	5.0 ~ 45	7.5 ~ 65	10 ~ 90
25A	0.8 ~ 4.0	1.0 ~ 5.0	8.0 ~ 80	11 ~ 110	15 ~ 150
32A	1.5 ~ 6.5	1.2 ~ 6.4	12 ~ 130	18 ~ 180	25 ~ 250
40A	1.0 ~ 9.0	2.0 ~ 10	16 ~ 180	22 ~ 250	32 ~ 340
50A	3.0 ~ 15	4.0 ~ 20	25 ~ 290	35 ~ 400	50 ~ 550
65A	5.0 ~ 24	6.0 ~ 32	45 ~ 460	65 ~ 650	90 ~ 900
80A	6.0 ~ 32	8.0 ~ 42	60 ~ 650	74 ~ 900	120 ~ 1200
100A	10 ~ 55	16 ~ 80	100 ~ 1100	140 ~ 1500	200 ~ 2100
125A	12 ~ 80	25 ~ 125	150 ~ 1700	220 ~ 2400	300 ~ 3300
150A	16 ~ 120	35 ~ 180	210 ~ 2400	300 ~ 3400	400 ~ 4500
200A	35 ~ 200	60 ~ 320	380 ~ 4200	500 ~ 5500	750 ~ 8000
250A	50 ~ 300	90 ~ 480	550 ~ 6500	800 ~ 9000	1100 ~ 12000
300A	65 ~ 450	160 ~ 820	900 ~ 9000	1200 ~ 12000	1700 ~ 17000
350A	85 ~ 550	200 ~ 1000	1100 ~ 11000	1600 ~ 16000	2200 ~ 22000
400A	120 ~ 700	300 ~ 1500	1500 ~ 15000	2100 ~ 21000	2800 ~ 28000
450A	160 ~ 1000	400 ~ 2000	1800 ~ 19000	2600 ~ 2700	3500 ~ 36000
500A	350 ~ 1200	500 ~ 2500	2200 ~ 24000	3200 ~ 33000	4200 ~ 45000

We are here for you

For further information, visit us at

www.maxiflo.co.kr

The information contained in this catalog contains merely general descriptions or characteristics of performance which in case of actual use do not always apply as described or which may change as a result of further development of the products. An obligation to provide the respective characteristics shall only exist if expressly agreed in terms of the contract.

All product designations may be trademarks or product names of Seil Enterprise Co. whose use by third parties for their own purposes could violate the rights of the owners.

Seil Enterprise Co.

Seoul Korea
www.maxiflo.co.kr

MAXIFLO™ is a registered trademark of Seil Enterprise Co.